

NUMBER 201589

USED ON

- OBSOLETE** 201589 -1 1. AS SHOWN.
- OBSOLETE** 201589 -2 1. SAME AS -1 EXCEPT;
2. FINISH OF ITEM 1, .0001 MIN SILVER OVER .00005 MIN NI
- OBSOLETE** 201589 -3 1. SAME AS -1 EXCEPT;
2. FINISH OF ITEM 1, .0001 MIN GOLD OVER .0001 MIN SILVER
- OBSOLETE 201589 -4** 1. SAME AS -1 EXCEPT;
2. MTD ON TAPE.

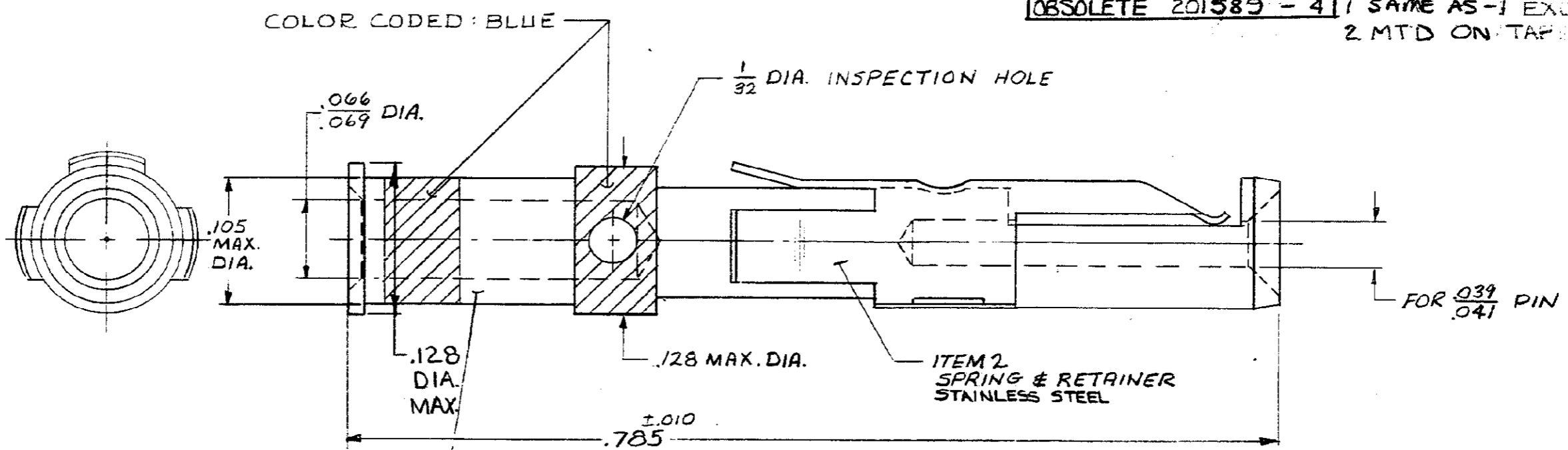

ITEM 1
SOCKET BODY
COPPER ALLOY
.00003 MIN GOLD OVER .00005 MIN NICKEL

WHEN ORDERING CONTACT ON TAPE, ORDER BY THE TAPE NUMBER PLUS THE PACKAGING CODE AS FOLLOWS:

1. FOR USE WITH AMP TAPETRONIC, PNEUMATIC TOOL—
 - A. 1000 PARTS TO A BOX ADD PACKAGING CODE: 1MBOX
2. FOR USE WITH 4/8 INDENT STRIPPER CRIMPER—
 - A. 1000 PARTS TO A REEL ADD PACKAGING CODE: 1MREEL
 - B. 5000 PARTS TO A REEL ADD PACKAGING CODE: 5MREEL

DIMENSIONS IN INCHES. DO NOT SCALE PRINT.
PROPOSAL NO. C/PW-461-X13

PRINT DIST. 3913

REV	DESCRIPTION	DATE	BY	CHECK
M	06S-24-3 ECN BD3038	2.6.10.87		
L	REV PER ECN BD2619	11.13.89		
K	OBSOLETE -4 PER	3.43.90	MWD	12-87
J	REVISED	5.4.92	THW	9-87
H	INACTIVATED -4	J.003		
G	REV. PER ECN	8.838		
F	NOTE ADDED	1.14.1		
E	REV RETAINER SPRING TO SST	2.20.8		
D	REVISED	3.6.1		
C	REVISED	W-525		
B	REVISED	4.5		
A	REVISED	5.34		
LTR	REVISION RECORD	ECA		

REF: 1950-317-35

© 1961 BY AMP INC. HARRISBURG, PENNA.
AMP PATENTS COVERED BY PATENTS
U.S. PATENT OFFICE

MATERIAL SEE CALL OUT	DR J. Ruff 11-10-61	ENGR J. S. [unclear] 11-16-61
HEAT TREAT H	CHK J. [unclear] 11-30-61	APP J. Ruff 11/16/61
AMP AMP INCORPORATED HARRISBURG, PENNA.		
FINISH SEE CALL OUT		
NAME #20 SOCKET CONTACT ASSY		
WIRE SIZE 18-16		
SCALE 10:1	LOC BD	NO 201589
		REV M

TO
EXCEPT AS NOTED
DECIMALS = 0.001
FRACTIONS = 1/32